

Electronic Cruise Control for Honda ST1100 Pan European



The following provides a brief description of the power consumption and component locations of the MotorCycle Setup electronic cruise control.

Installed weight of the cruise control is approximately 1.8kg.

Current draw while the cruise is switched on, but not engaged, is approximately 0.250 amp (3 watts). Current draw while the cruise is engaged is nominally 0.50~0.80 amp (6~10 Watts).

By comparison, a head light bulb typically draws about 4 amps (55 Watts), and a tail light bulb (running light) draws about 0.4 amp (5 Watts).

Refer to the line drawing on the back of this sheet to identify the components from the numbers in the text.

The **Computer (1)** mounts in the rear luggage compartment under the seat. It is positioned in the top of the compartment in a **foam block (2)**.

The **Actuator (3)** is bolted to the bottom of the rear luggage compartment and sits in the left hand bottom corner of the compartment. A single 6.5mm (1/4") hole must be drilled in the bottom of the luggage compartment to mount the actuator. A **vacuum hose assembly (4)** is provided to connect the actuator to the engine.

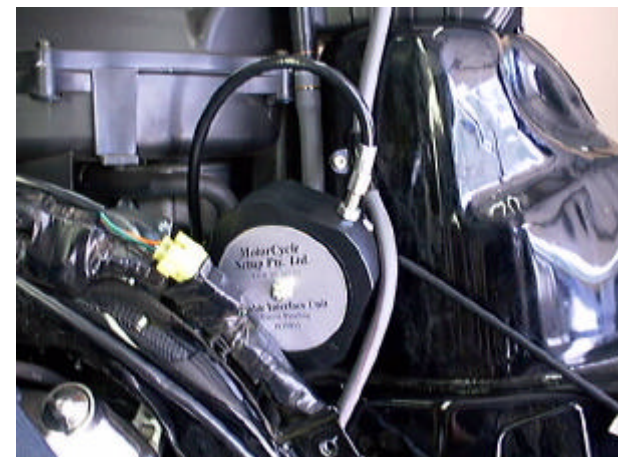

The **Cable Interface Unit (5)** is located under the top shelter (false fuel tank) next to the left hand side of the extension of the fuel tank that contains the filler neck and has a new **cable (6)** running from it to the carburetors.

The **Speed sensor (7)** is mounted on the left hand side of the swing arm. The original axle pinch bolt is removed and a new bolt screwed in from the bottom with the sensor bracket attached to it. A Nyloc nut is supplied to pinch the axle. Nickel plated magnets are placed in the heads of the bolts that mount the brake disc.



The **Control Switch (8)** is mounted to the left hand (clutch) master cylinder handlebar clamp. The bracket mounts between the bottom faces of the clamp and the master cylinder. The clamp must have about 1~1.5mm (0.040"~0.060") filed from the bottom face to allow for the thickness of the switch bracket.

The **Wiring Loom (9)** uses the same type of plugs that are already used on the motorcycle. Power for the cruise control and brake sensing is taken off the brake light switches by unplugging the rear brake light switch. Matching connectors on the cruise control loom are plugged in to the switch and the bike's loom. Tach (engine speed) sensing is detected from the bike's ignition coils. This is used to disengage the cruise if the clutch is operated. The cruise control is grounded on the battery negative terminal.

The wiring loom incorporates a new safety device, the 'CruiseSafe' actuator power relay. This device is a simple relay that is operated by the brake light switches. If the cruise control should malfunction, either due to electrical interference or component failure, applying the brakes enough to turn the brake light on will instantly cut power to the cruise control actuator (servo). Releasing the brakes will restore power to the actuator. This device is fail-safe in all respects except one. The brake light switches must be operative for this device to work.

We have seen several bikes with accessories such as a CB radio fitted in the top of the rear luggage compartment. We do NOT recommend placing the CB radio in this location due to the potential for interference with the cruise control electronics.

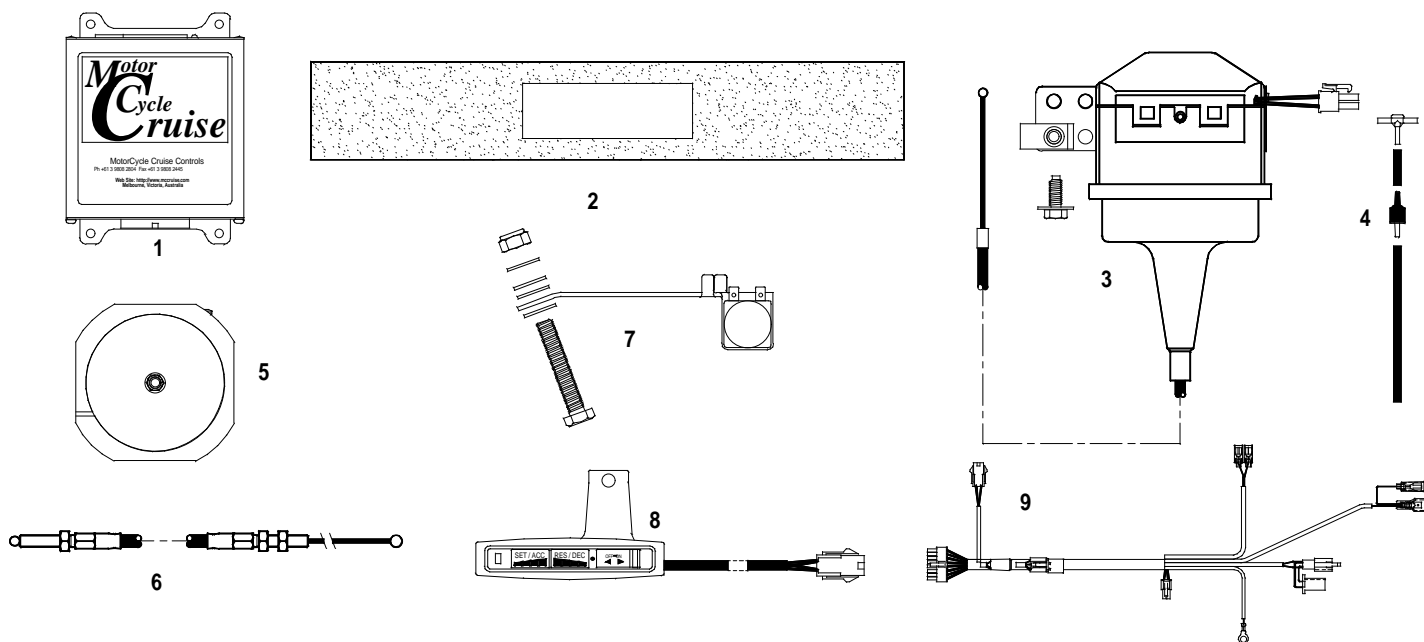

MotorCycle Setup P/L

ABN 94 798 167 654

6 Kinston Street
Mount Waverley VIC 3149
AUSTRALIA

Web Site: <http://www.mccruise.com>

International: Phone (International Access Code) 61 3 9808 2804

Fax (International Access Code) 61 3 9808 2445

Australia: Phone (03) 9808 2804

Fax (03) 9808 2445

E-mail: mcsetup@bigpond.net.au